

816CAN Generic CAN Interface



Introduction

The 816CAN is an E-Plex/CAN gateway that allows bidirectional communications between E-Plex and a wide variety of CAN networks. These may be for example CANopen, J1939, or other proprietary CAN systems. The CAN bus is galvanically isolated to ensure reliable communications between systems running from different power sources. Using E-Logic, the system designer has full control over how CAN messages are constructed, and when they are sent. Receive filters can also be configured in order to minimise the required amount of message processing.



Key features

- EP3 connector.
- 2.5kV RMS isolation between E-Plex and CAN systems.
- Supports a wide range of CAN baud rates, up to 1Mbps.
- Dedicated VE.CAN interface using RJ45 jack for data communication with Victron Energy products.
- Incoming CAN message filtering using E-Logic.
- Custom outgoing CAN message generator using E-Logic.
- 6-way Phoenix plug for external power, and CAN in and out for daisy chained connections, or bus termination.

Electrical specifications

Description	Minimum	Nominal	Maximum
E-Plex LEN	-	4	-
External Power Voltage (V+/V-)	6 VDC	12 / 24 VDC	32 VDC
Current	20 mA	-	40 mA
CAN baud rate	10 kbps	-	1000 kbps
CANH, CANL	-27 V	-	40V

Supported CAN baud rates

The 816CAN can generate a wide range of standard baud rates with a high degree of accuracy. It can also approximate a wide range of non-standard baud rates to within the tolerances specified by the CAN standard. Refer to the 816CAN unique properties dialogue in E-Logic for more information.



Wiring details

6-way phoenix socket

Pin	Description
1	CAN Data High
2	CAN Data Low
3	CAN Data High (directly connected to pin 1)
4	CAN Data Low (directly connected to pin 2)
5	Network V+ (12/24V nominal)
6	Network V- (0V)

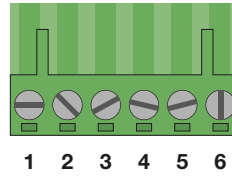

Please note:

- In order for the CAN interface to work, pins 5 and 6 must be connected to 12/24V nominal power supply. These pins power the isolated CAN side of the module, and should be connected to the supply that powers the other CAN devices.
- Pins 3 and 4 are provided to allow easy daisy-chaining of CAN modules. Alternatively, if the module is at the end of a cable run, they may be used for connecting a bus termination resistor.

Bus termination

The CAN bus backbone must be terminated at each end with a 1/4 W resistor no matter how short the cable (short drops off the backbone are permitted without termination). The 816CAN is supplied with a 120 Ω resistor already fitted. This is suitable for buses up to approximately 40 m. For longer buses, the value of the termination resistor should be adjusted to match the characteristic impedance of the bus cabling.

RJ45 socket

Pin	Description	Colour
1	Not connected	
2	Not connected	
3	NET-C V- (Network 0V power supply)	
4	Not connected	
5	Not connected	
6	NET-S V+ (Network 12/24V nominal power supply)	
7	CAN Data High	
8	CAN Data Low	

12345678

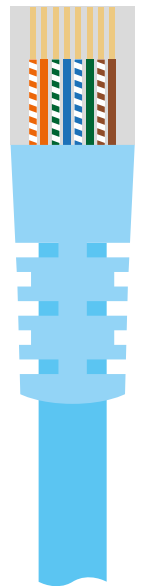

This connector may be used for interfacing with Victron equipment fitted with VE.CAN interfaces.

LED indicators

LED Function	Description
Receive	Flashes each time a frame is received from the CAN bus
Transmit	Flashes each time a frame is transmitted onto the CAN bus
External Power	Illuminates when a power supply is applied to the external power terminals
E-Plex Ack	Flashes each time the module sends a message onto the E-Plex bus

Mechanical specifications

Description	Specifications
Operating Temperature	-20°C to 60°C (non freezing)
Storage Temperature	-40°C to 85°C
Operating Humidity	5% to 95% (non-condensing)
IP Rating	IP20

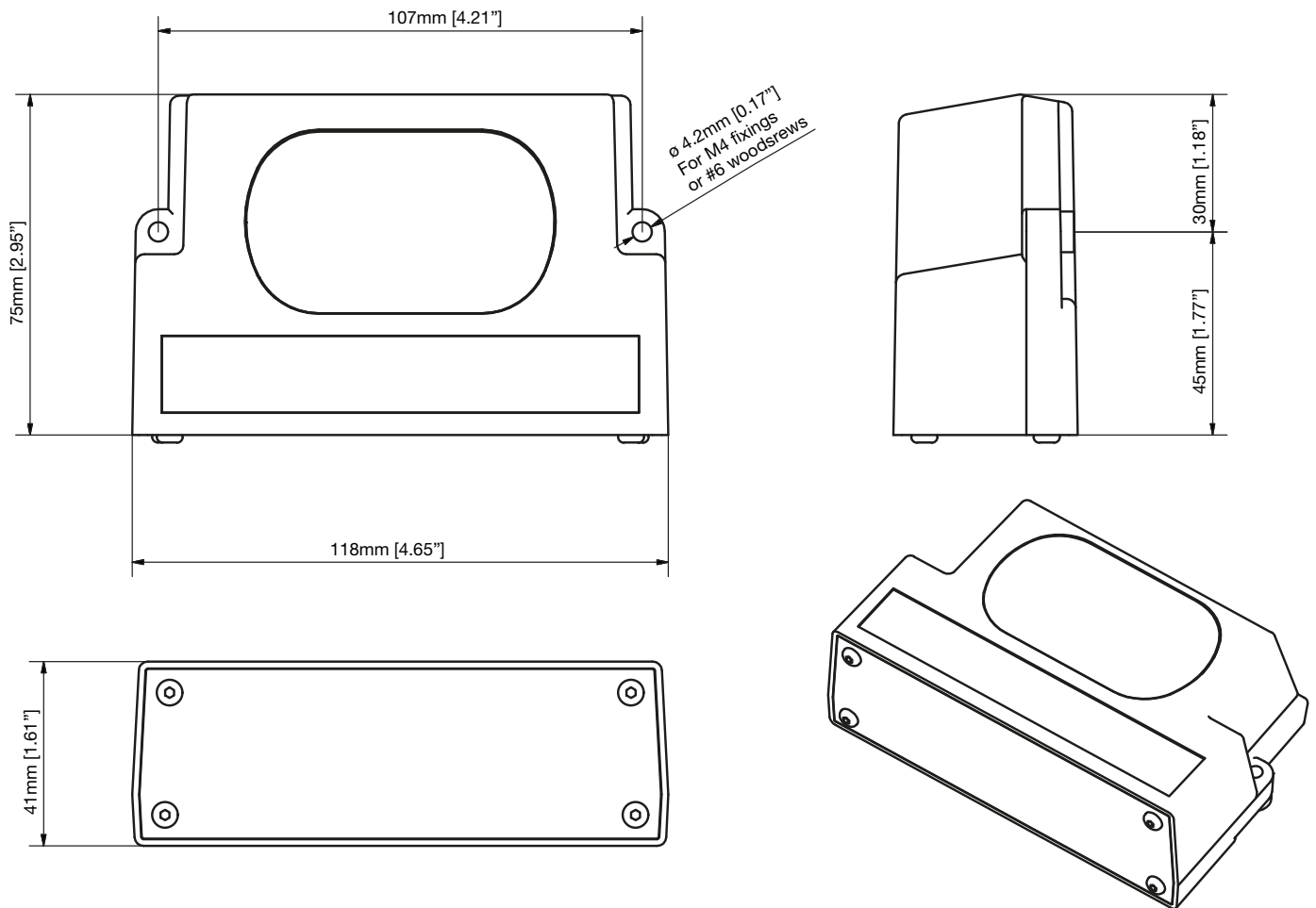

Ordering codes

Description	Ordering Code
816CAN Generic CAN Interface	EP3-INTER-816CAN



52 – 54 Riverside, Sir Thomas Longley Road, Medway City Estate, Rochester, Kent ME2 4DP
tel: +44 (0)1634 711622 fax: +44 (0)1634 290773

email: sales@e-plex.co
web: www.e-plex.co

Important Notice: E-Plex Ltd. (E-Plex) reserves the right to make changes to or discontinue any product or service identified in this publication without notice. E-Plex advises its customers to obtain the latest version of the relevant information to verify, before placing any orders, that the information being relied upon is current. E-Plex assumes no responsibility for infringement of patents or rights of others based on E-Plex applications assistance or product specifications since E-Plex does not possess full access concerning the use or application of customers' products. E-Plex also assumes no responsibility for customers' product designs.